

MiniMc Series

DS-MiniMc-1313
© 2013 B&B Electronics. All rights reserved.

SWITCHING 10/100 MINIATURE FIBER MEDIA CONVERTERS

The MiniMc Series offers the most reliable and cost-effective switching 10/100 Mbps miniature media converters in the industry.

B&B ELECTRONICS



Features and Benefits

The most cost-effective miniature fiber converters available

- 10/100 Mbps switching MiniMc connects 10 or 100 Mbps copper to 100 Mbps fiber (fixed or SFP version)
- 6-year comprehensive warranty on converter and power adapter

Plug-and-Play Operation

- User-friendly 10/100 Mbps Auto Negotiation technology on MiniMcs
- AutoCross feature for twisted pair connection on all converters

Perfect for a variety of applications

- MiniMcs include country-specific, high-reliability AC power adapters and can also be powered with an optional USB-power cable
- Available with multi-mode fiber or single-mode fiber, single-strand fiber, CWDM fiber and SFP connectors

Space saving features

- Compact, metal enclosures with external AC power adapters
- IE-PowerTray/18-AC chassis supports up to 18 modules in the 1.5U high, rack-mountable enclosure

Media conversion is the most cost-effective solution for extending the productive life of legacy wiring plants and equipment while allowing implementation of new technologies. Measuring less than 3.5 inches deep and 2 inches wide, the MiniMc-Gigabit and Giga-MiniMc are one of the industry's smallest media converters with both data connections on the same side of the unit. An optional fiber SFP port gives network operators the flexibility to upgrade network equipment to different fiber interfaces.

Designed and manufactured in the USA, the MiniMc Series extends 10 and 100 Mbps twisted pair network segments up to 80 km over fiber

Both a media and data rate converter, the MiniMc features 10/100 Auto Negotiation on the copper port while the fiber port operates at 100 Mbps full duplex. MiniMc 10/100 switching fiber converters are ideal for all premises, FTTD, LAN-to-LAN or LAN-to-MAN fiber networking applications.

Multiple powering options include a country-specific AC wall adapter or USB-power cord. The unit can also be installed into the IE-PowerTray/18-AC which allows for 18 conversions in only 1.5U of rack space, or mounted .

The MiniMc 10/100 fiber media converters are backed with a 6-year comprehensive warranty that includes the power supply.

Application Example

This common application depicts a wiring closet housing a copper switch which is paired to the high-density IE-PowerTray/18-AC populated with MiniMc's. The copper is converted to fiber and then run to another MiniMc, converting the data back to copper, in a local Fiber-to-the-Desk set-up. A second drop shows a remote copper switch connected to the switch in the wiring closet.

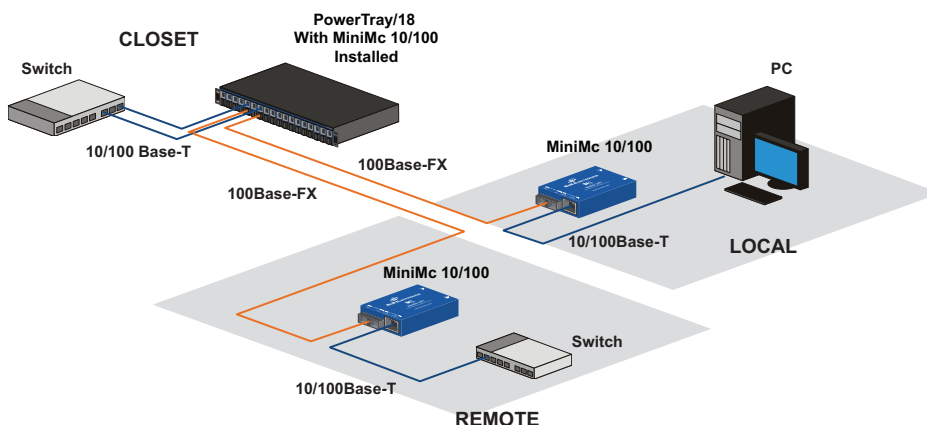

PRODUCT INFORMATION

Technical Specifications

- IEEE 802.3 10Base-T twisted pair
- IEEE 802.3u 100Base-TX twisted pair
- Supports jumbo packets up to 1916 bytes
- Plug-and-play operation
- RJ-45, ST or SC and SFP connectors available 50/125µm or 62.5/125µm multi-mode fiber
- 9/125µm single-mode fiber
- Available with single-strand fiber support
- Country-specific, high-reliability power adapter
- Auto Negotiation, Auto-Cross for MDI/MDIX
- Status LEDs

Regulatory Approvals:

- FCC Class B
- UL/cUL, CSA, CE

Dimensions:

0.83"H x 1.80"W x 3.35"D
(2.11 x 4.57 x 8.51 cm)

Shipping Weight:

0.7 lbs (.317 kg)

Power Rating:

5 VDC, 500mA

Operating Temperature:

+32° F to +122° F (0° C to +50° C);
5% to 95% (non-condensing)

AC Adapter:

+32° F to +122° F (0° C to +50° C);

Storage Temperature:

-31° F to +167° F (-35° C to +75° C);
5% to 95% (non-condensing)

IE-PowerTray/18-AC

- 18 slots for powering converters
- 1.5U high, rack mountable enclosure

Regulatory Approvals:

- FCC Class B
- UL/cUL, CSA, CE

Dimensions

2.30"H x 16.97"W x 9.25"D
(5.80 x 43.10 x 23.5 cm)

Shipping Weight

10 lbs (4.5 kg)

Power Information

AC Input Load: 100-240V AC,
50/60 Hz, 1.5A

Operating Temperature

-4° to +158° F
(-20° to +70° C);
5% to 95% (non-condensing)

Storage Temperature

-40° to +185° F
(-40° to +85° C);
5% to 95% (non-condensing)



Ordering Information

PART NUMBER	DESCRIPTION	DISTANCE
MiniMc 10/100 ¹		
855-10619	MiniMc, TP-TX/SFP ***	Varies
855-10620	MiniMc, TP-TX/FX-MM850-ST	2 km
855-10621	MiniMc, TP-TX/FX-MM850-SC	2 km
855-10622	MiniMc, TP-TX/FX-MM1300-ST	5 km
855-10623	MiniMc, TP-TX/FX-MM1300-SC	5 km
855-10624	MiniMc, TP-TX/FX-SM1310/PLUS-ST	40 km
855-10625	MiniMc, TP-TX/FX-SM1310/PLUS-SC	40 km
855-10626	MiniMc, TP-TX/FX-SM1310/LONG-ST	80 km
855-10627	MiniMc, TP-TX/FX-SM1310/LONG-SC	80 km
855-10641	MiniMc, TP-TX/FX-SM1550/LONG-SC	80 km
MiniMc 10/100 Single-Strand Fiber ***		
855-10650	MiniMc, TP-TX/SSFx-MM1300-SC	2 km
855-10651	MiniMc, TP-TX/SSFx-MM1550-SC	2 km
855-10652	MiniMc, TP-TX/SSFx-SM1310-SC	20 km
855-10653	MiniMc, TP-TX/SSFx-SM1550-SC	20 km
855-10654	MiniMc, TP-TX/SSFx-SM1310/PLUS-SC	40 km
855-10655	MiniMc, TP-TX/SSFx-SM1550/PLUS-SC	40 km
855-10656	MiniMc, TP-TX/SSFx-SM1310/LONG-SC	60 km
855-10657	MiniMc, TP-TX/SSFx-SM1550/LONG-SC	60 km

CWDM wavelengths are also available. Contact IMC Networks for availability.

¹ To order modular versions without an AC adapter, change the first three numbers to "854".

** These products have single-strand fiber technology. Deploy in pairs, or connect to another compatible IMC Networks single-strand fiber product.

*** Requires one SFP/155 Module. SFP modules are sold separately.

PART NUMBER	DESCRIPTION
IE-PowerTray/18-AC	
850-13086	IE-PowerTray/18-AC (1.5U high, Rack-mountable Enclosure)
Accessories	
806-39105	DIN Rail Clip
895-39229	Wall Mount Bracket
806-39628	36" USB Power Cable for MiniMc
806-39629	12" USB Power Cable for MiniMc
806-39720	AC Power Adapter (10 Watt, 0° to +50° C) - FranMar
806-00720-00	USA Power Adapter Clip - FranMar
806-00720-01	UK Power Adapter Clip - FranMar
806-00720-02	Europe Power Adapter Clip - FranMar
806-00720-03	Australia/NZ Power Adapter Clip - FranMar

ISO 9001:2008
REGISTERED

6-YEAR
Comprehensive
Warranty



www.bb-elec.com orders@bb-elec.com support@bb-elec.com
International Office: 707 Dayton Road PO Box 1040 Ottawa, IL 61350 USA 815-433-5100 Fax 815-433-5104
California Office: 25531 Commercentre Dr. #210 Lake Forest, Ca. 92630 USA 949-465-3000 Fax 949-465-3020
European Office: Westlink Commercial Park Oranmore Co. Galway Ireland +353 91 792444 Fax +353 91 792445