

THIS DRAWING IS UNPUBLISHED. RELEASED FOR PUBLICATION  
 © COPYRIGHT BY TYCO ELECTRONICS CORPORATION. ALL INTERNATIONAL RIGHTS RESERVED.

LOC	DIST	REVISIONS					
GP	00	P	LTR	DESCRIPTION	DATE	DWN	APVD
			K1	REV PER ECO-10-011095	26MAY2010	RG	SM

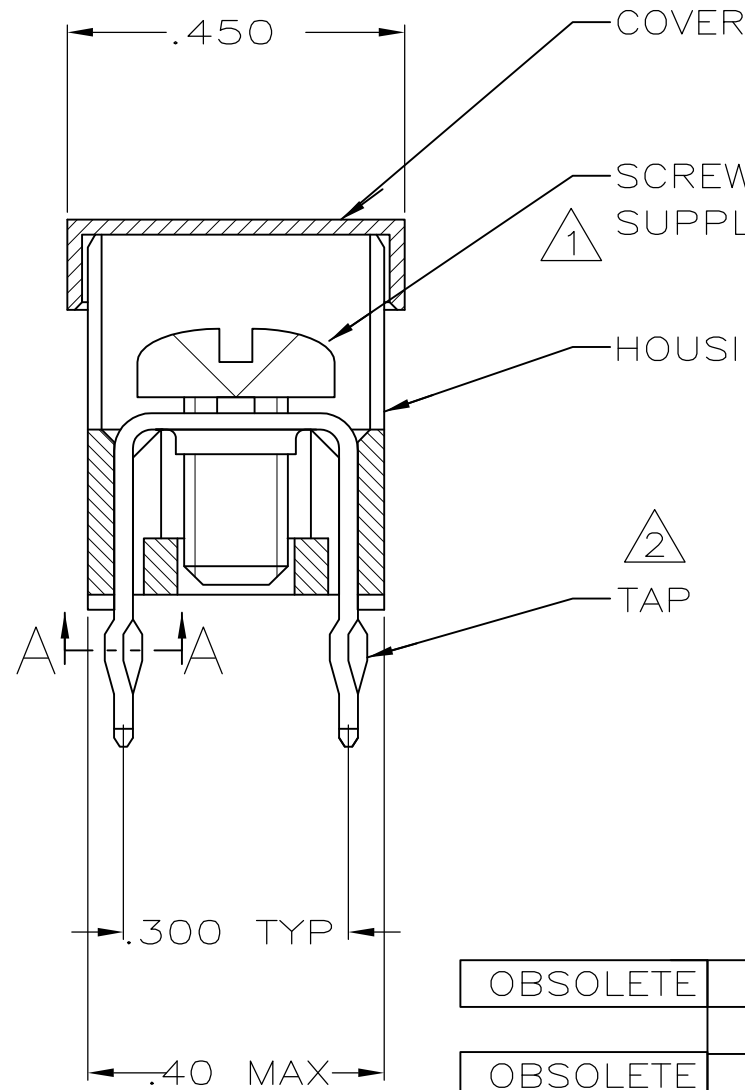
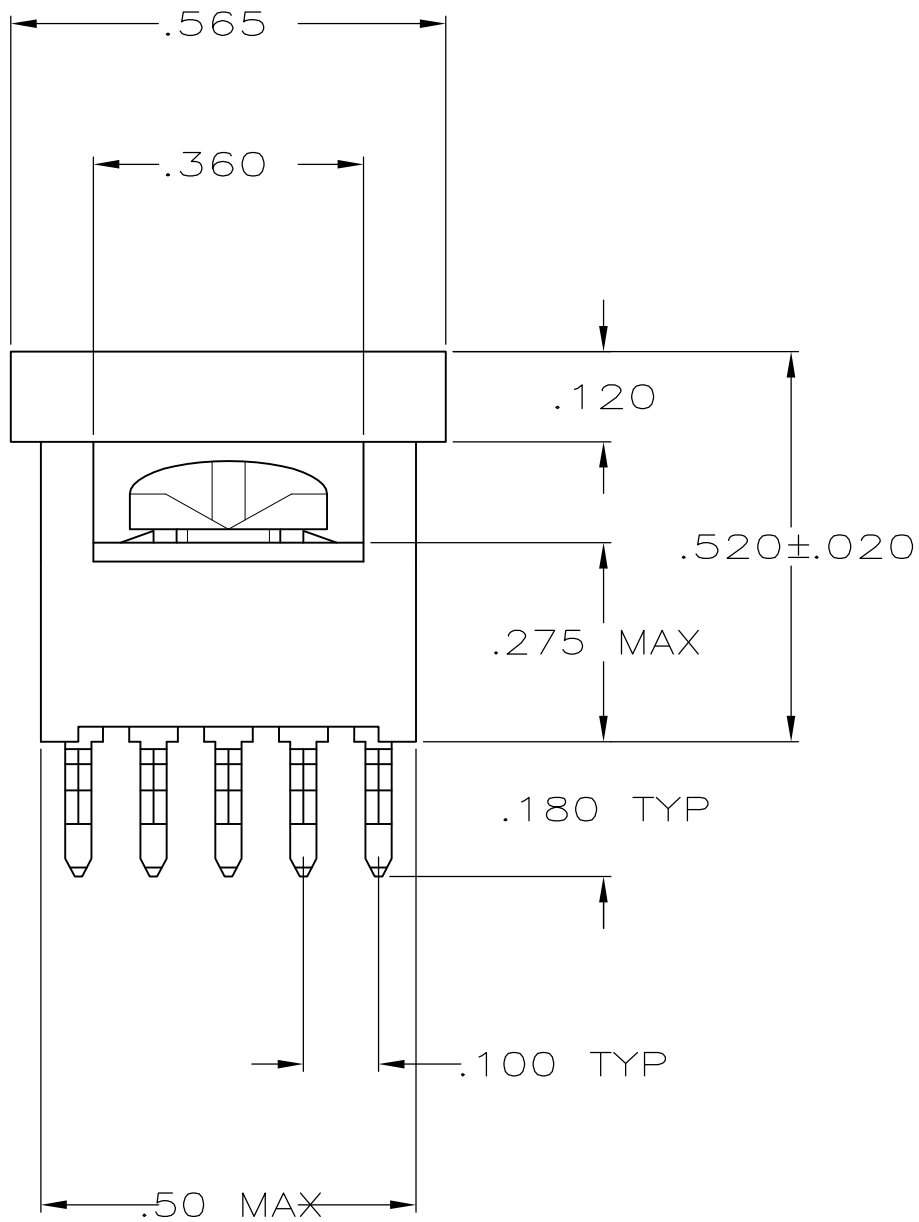

- ① TO PREVENT THREAD STRIPPING, SCREW TORQUE SHOULD NOT EXCEED 9 IN LBS.
- ② TAP HOLE IS 6-32UNC-2B, TWO MIN THREADS.
- ③ PACKAGED BULK.
- ④ PACKAGED INDIVIDUALLY.

OBSOLETE	④	YES	YES	55557-5
OBSOLETE	③	YES	YES	55557-4
OBSOLETE	③	YES	NO	55557-3
OBSOLETE	-	NO	YES	55557-2
OBSOLETE	-	NO	NO	55557-1
	PACKAGING	HOUSING AND TAP ASSEMBLED	SCREW	PART NO.



SECTION A-A  
 SCALE 10:1  
 10 PLACES

THIS DRAWING IS A CONTROLLED DOCUMENT.

DIMENSIONS: INCHES	TOLERANCES UNLESS OTHERWISE SPECIFIED:	DWN J. McCLINTON 1/11/88	Tyco Electronics Corporation Harrisburg, PA 17105-3608	
0 PLC ± -	1 PLC ± -	CHK R. STONE 1/11/88	TAP ASSEMBLY, POWER DISTRIBUTION	
2 PLC ± -	3 PLC ± .010	APVD M. GALLOWAY 1/15/88	NAME	
4 PLC ± -	ANGLES ± -	PRODUCT SPEC	SIZE	CAGE CODE
MATERIAL HOUSING: NYLON TAP: COPPER-ALLOY 725, .025 THICK	FINISH TAP: .000150 TIN-LEAD OVER .000050 NICKEL	APPLICATION SPEC	RESTRICTED TO	
		WEIGHT -	A3	00779
		CUSTOMER DRAWING	C=	55557
		SCALE 4:1	SHEET 1 OF 1	REV K1