

- NOTES:
- MATERIALS AND FINISHES:
 COUPLING NUT, CLAMP NUT- STAINLESS STEEL, PASSIVATED
 HOUSING - STAINLESS STEEL, GOLD PLATED
 CONTACTS - BeCu, GOLD PLATED
 INSULATORS - PTFE
 - ELECTRICAL:
 A. IMPEDANCE: 50 OHM
 - MECHANICAL:
 A. DURABILITY: 500 CYCLES MIN.
 B. TEMPERATURE RANGE: -65 C TO +165 C
 - PACKAGING:
 A. QUANTITY: SINGLE PACK
 B. MARKING: BAG TO BE MARKED
 "AMPHENOL RF, 901-B5604-2478 , AND DATE CODE
 - SHOWS CABLE ENTRY DIMENSIONS.
 - CABLE ASSEMBLY INSTRUCTIONS:
 A. TRIM CABLE AS SHOWN.
 B. SLIDE CLAMP NUT, WASHER, HOUSING, & FERRULE ONTO CABLE
 C. CRIMP FERRULE USING A .128 HEX DIE
 D. SLIDE INSULATOR ONTO CABLE
 E. CRIMP OR SOLDER BULLET CONTACT TO CABLE CENTER CONDUCTOR
 INSERT CABLE WITH BULLET CONTACT INTO BODY, WITH
 GUIDENCE OF PIN (ANTI-ROTATION PIN)
 F. APPLY THREAD LOCKING ADHESIVE ON THE THREADS OF THE CLAMP NUT
 G. TORQUE BACK NUT DOWN TO 15 IN-LBS

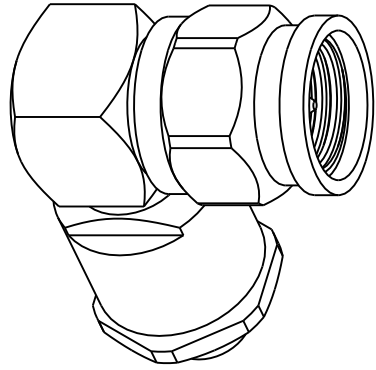

SCALE 3.000

901-B5604-2478		REVISIONS			
DRAWING NO.	REV	DESCRIPTION	DATE	ECO	APPR
THIRD ANGLE PROJ.	A	RELEASED TO MFG.	--	30592	--
	M	REDRAWN IN PROE	6/12/09	47524	PNE
	N	ADD CABKE STRIPPING, EXPLODED VIEW	8/2/10	48206	CPM
	P	STAMP WAS "74868 901-B5604-2478"	6/15/11	48626	CPM

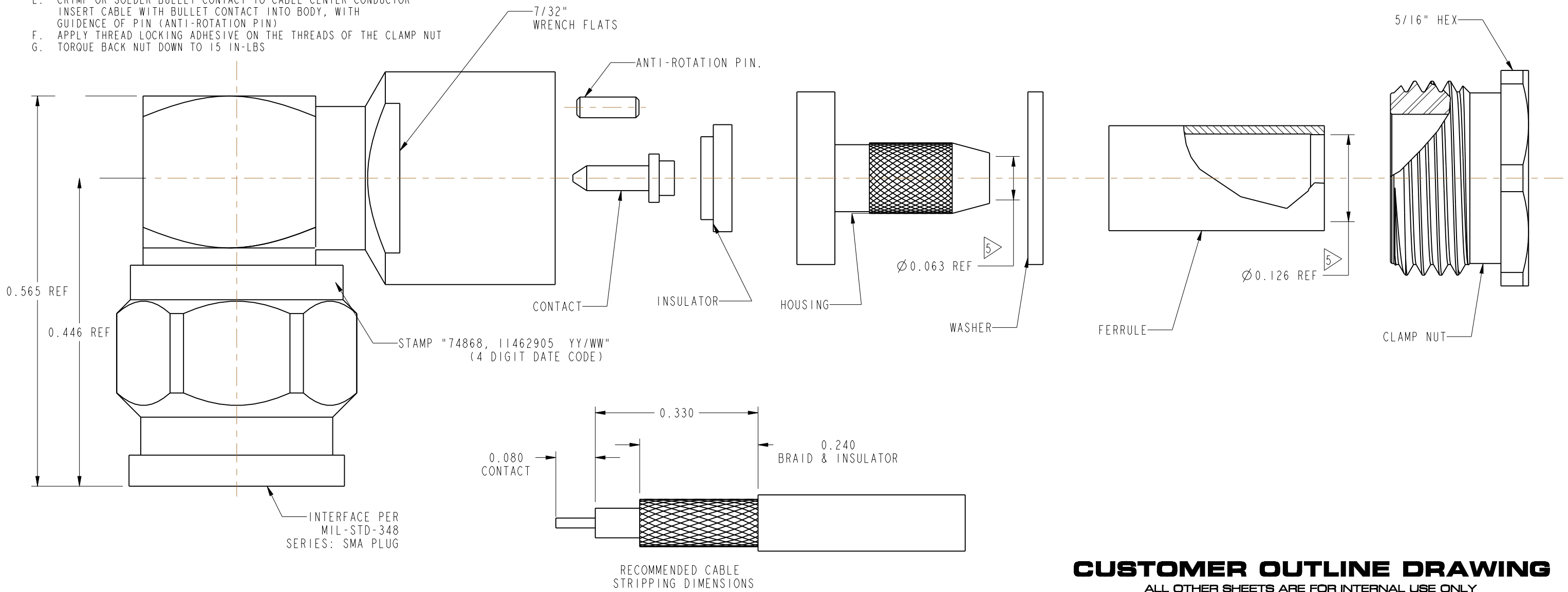

CUSTOMER OUTLINE DRAWING
 ALL OTHER SHEETS ARE FOR INTERNAL USE ONLY

UNLESS OTHERWISE SPECIFIED, DIMENSIONS ARE IN INCHES AND TOLERANCES ARE: 2 PLACE DECIMAL 3 PLACE DECIMAL ANGLES $\pm .015$ (0,381 mm) $\pm .005$ (0,127 mm) $\pm 1^\circ$	MATERIAL	DRAWN	DATE	TITLE		Amphenol RF Danbury, CT, USA Tainan, Taiwan Shenzhen, China www.amphenolrf.com	
	SEE NOTES	PADMANABHAN E	31-Mar-09				
NOTICE - These drawings, specifications, or other data (1) are, and remain the property of Amphenol Corp. (2) must be returned upon request; and (3) are confidential and not to be disclosed to any person other than those to whom they are given by Amphenol Corp. The furnishing of these drawings, specifications, or other data by Amphenol Corp., or to any other person to anyone for any purpose is not to be regarded by implication or otherwise in any manner licensing, granting rights or permitting such holder or any other person to manufacture, use or sell any product, process or design, patented or otherwise, that may in any way be related to or disclosed by said drawings, specifications, or other data.	REFERENCE	ENGINEER	DATE	SMA MALE R/A CRIMP CLAMP FOR RG 188 & 316 WITH EXTENDED FERRULE		SCALE: 7.0:1 SHEET 2 OF 2	
	RAYTHEON # 11462905	F.M	8-Apr-83				
			APPROVED	DATE	CODE ID	DWG SIZE	DRAWING NO.
		H. PARIKH	6/12/09	74868	B	901-B5604-2478	P
		CAD FILE		Root Folder/SMA/901-B5604-2478			